

CONSTRUCTION SIGN DETAILS

FED. ROAD DIST. NO.	STATE	PROJ. NO.	FISCAL YEAR	SHEET NO.	TOTAL SHEETS
8	N.D.			75	

D-754-71-2

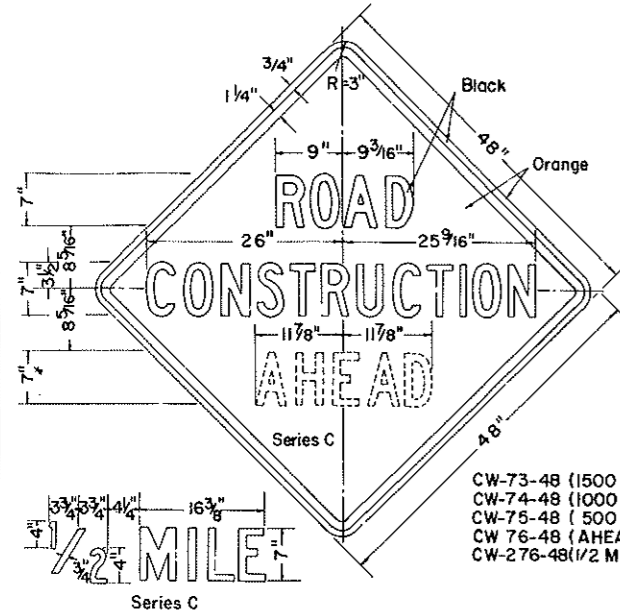

CW-73-48 (1500 FT.)  
 CW-74-48 (1000 FT.)  
 CW-75-48 (500 FT.)  
 CW-76-48 (AHEAD)  
 CW-276-48 (1/2 MILE)

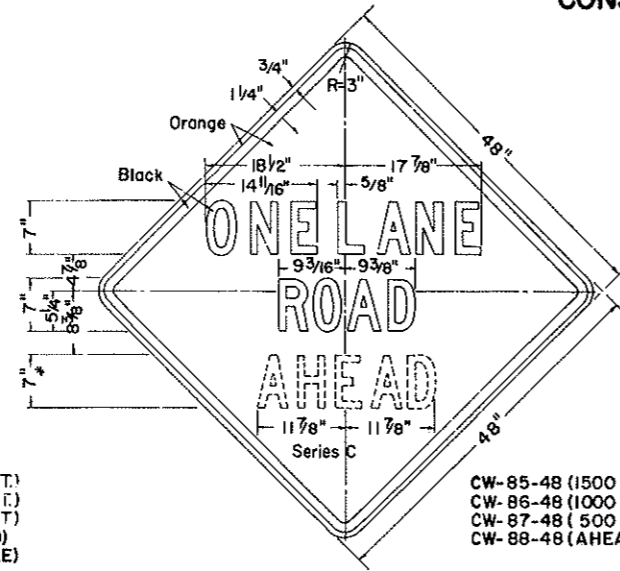

CW-85-48 (1500 FT.)  
 CW-86-48 (1000 FT.)  
 CW-87-48 (500 FT.)  
 CW-88-48 (AHEAD)

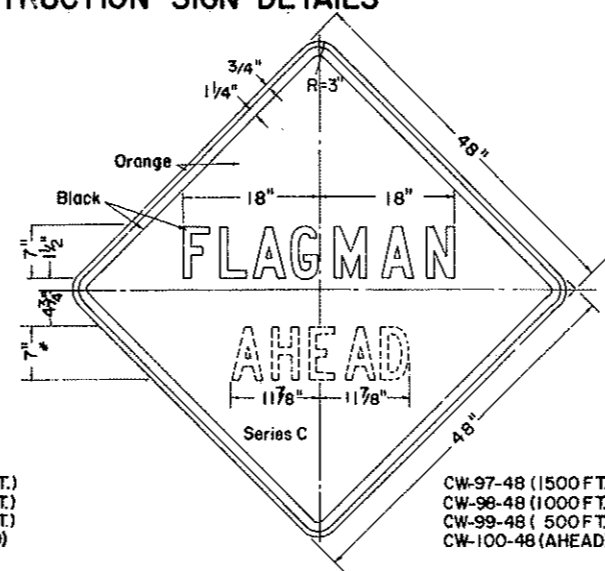

CW-97-48 (1500 FT.)  
 CW-98-48 (1000 FT.)  
 CW-99-48 (500 FT.)  
 CW-100-48 (AHEAD)

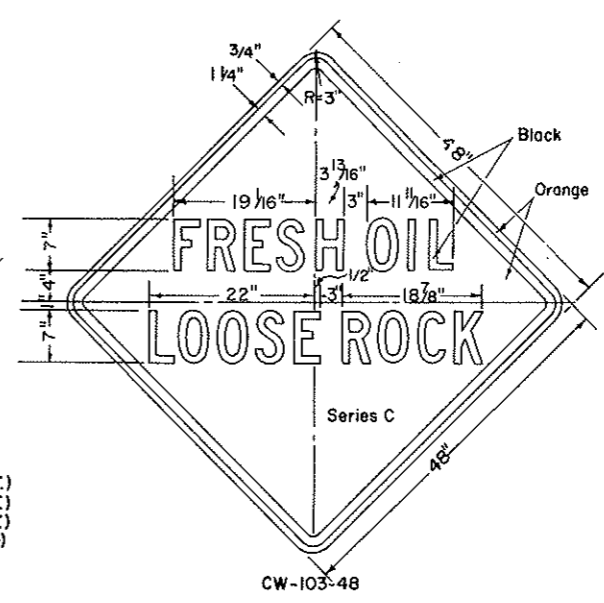

CW-103-48

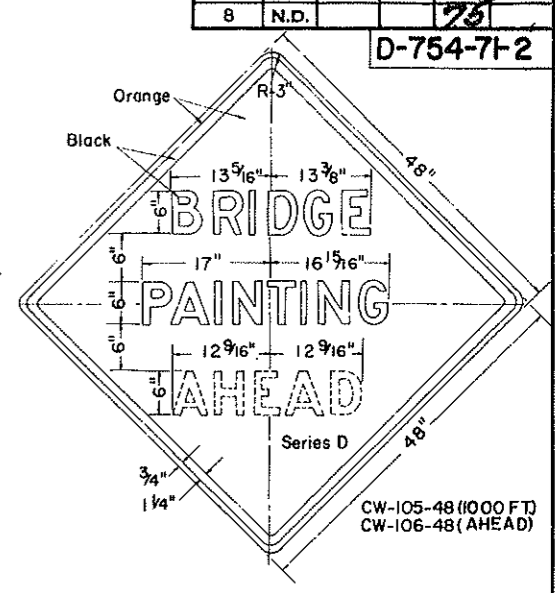

CW-105-48 (1000 FT.)  
 CW-106-48 (AHEAD)



Series C

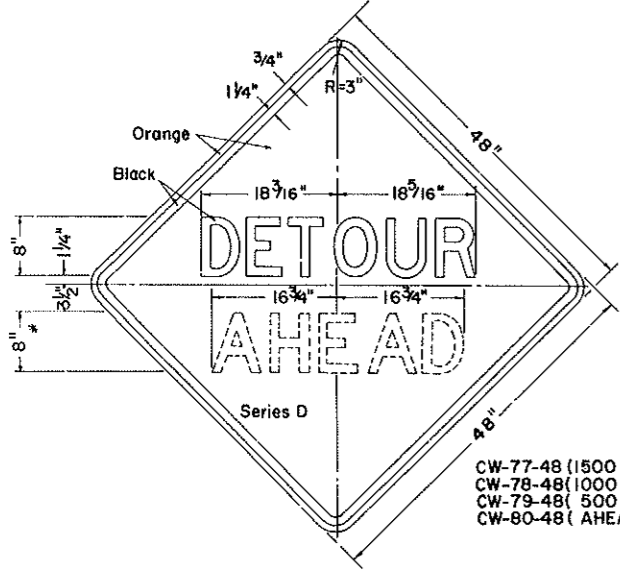

CW-77-48 (1500 FT.)  
 CW-78-48 (1000 FT.)  
 CW-79-48 (500 FT.)  
 CW-80-48 (AHEAD)

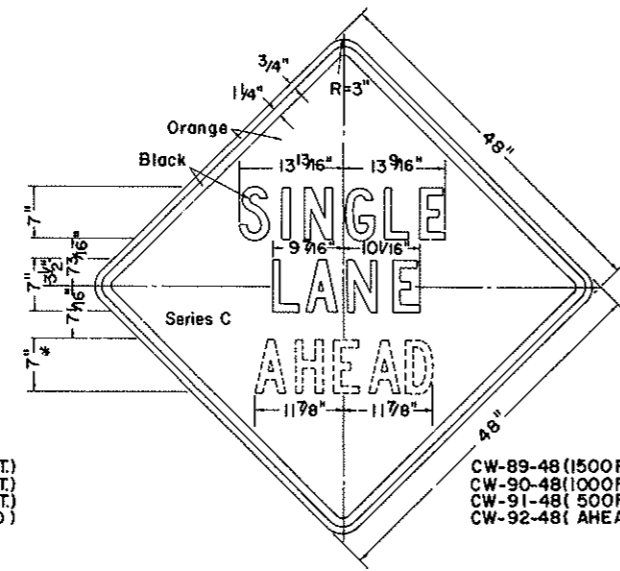

CW-89-48 (1500 FT.)  
 CW-90-48 (1000 FT.)  
 CW-91-48 (500 FT.)  
 CW-92-48 (AHEAD)

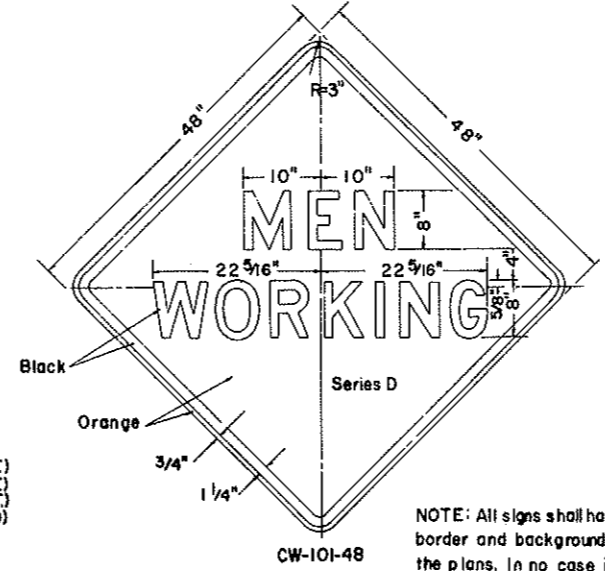

CW-101-48

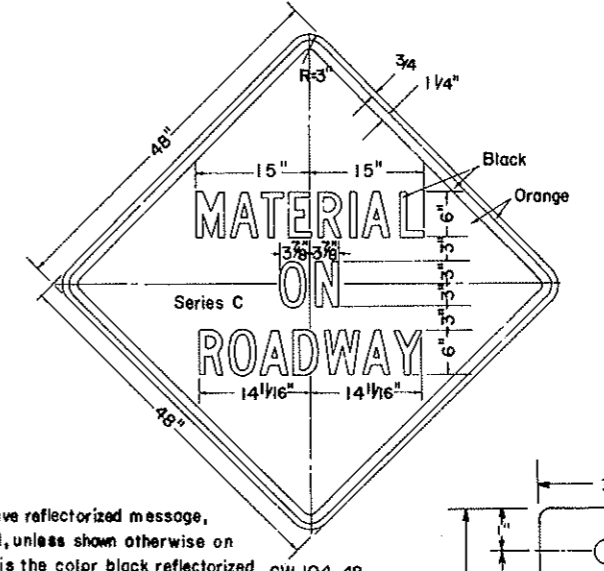

CW-104-48

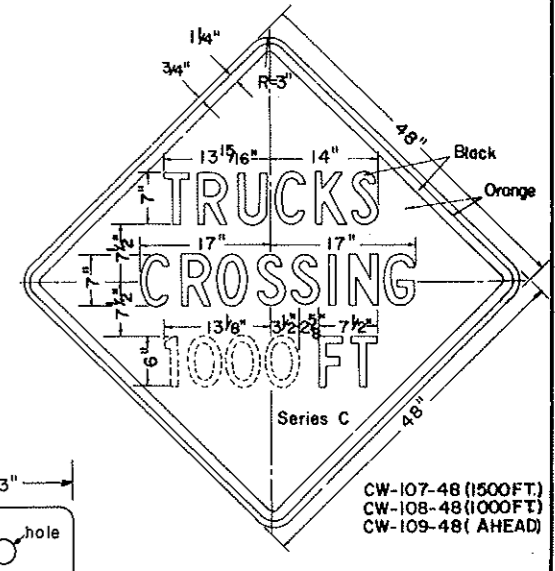

CW-107-48 (1500 FT.)  
 CW-108-48 (1000 FT.)  
 CW-109-48 (AHEAD)

NOTE: All signs shall have reflectorized message, border and background, unless shown otherwise on the plans. In no case is the color black reflectorized.  
 Material: See Std. D-754-71-5 for assembly details.

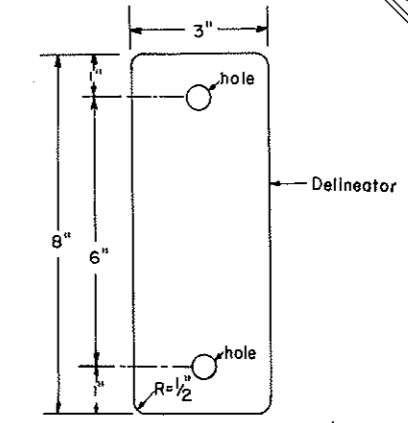

3 x 8" - 18 gauge sheet iron or steel, or .080" aluminum plate with Reflective Sheeting (enclosed lens) as specified in Section 894 of the Standard Spec.

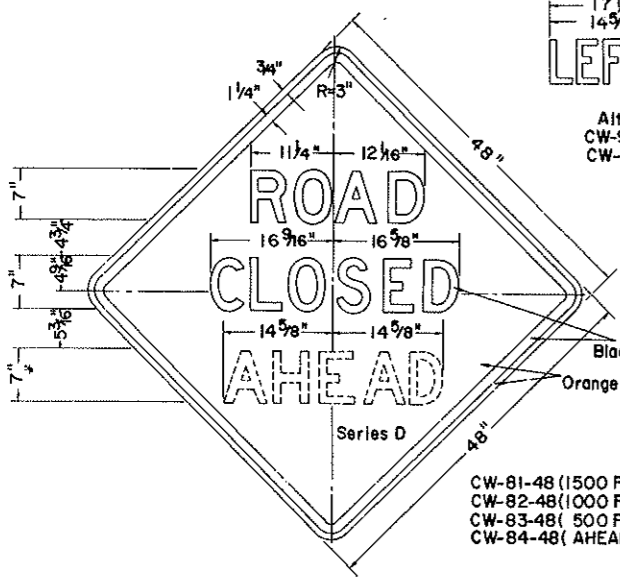

CW-81-48 (1500 FT.)  
 CW-82-48 (1000 FT.)  
 CW-83-48 (500 FT.)  
 CW-84-48 (AHEAD)

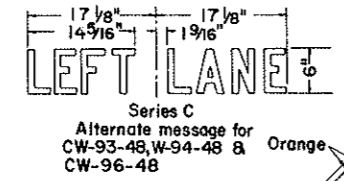

Series C  
 Alternate message for  
 CW-93-48, W-94-48 &  
 CW-96-48

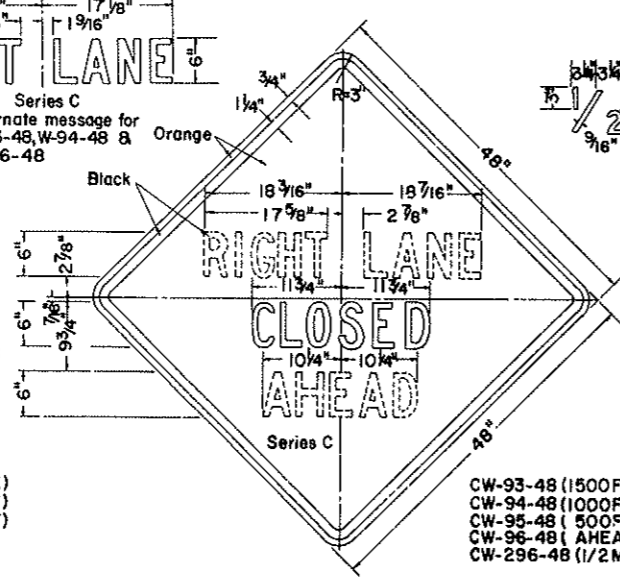

CW-93-48 (1500 FT.)  
 CW-94-48 (1000 FT.)  
 CW-95-48 (500 FT.)  
 CW-96-48 (AHEAD)  
 CW-296-48 (1/2 MILL)

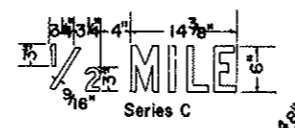

Series C

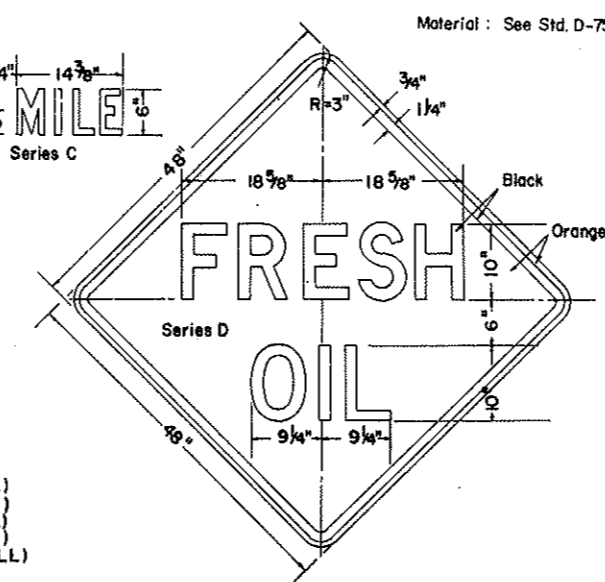

CW-102-48

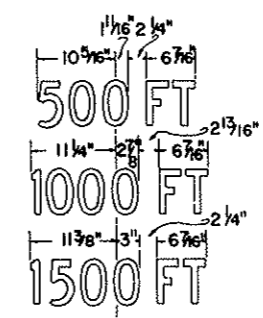

6" Series C  
 Alternate message for  
 all signs as indicated  
 \*Alternate message only  
 shall be 6" Series C

3-13-72		NORTH DAKOTA STATE HIGHWAY DEPARTMENT
REVISIONS		
DATE	CHANGE	Submitted: <i>R. Bloues</i> Design Engineer
3-7-75	Message on Construction Sign	
10-11-76	Delineator Detail Added	Recommended: Asst. Chief Engineer, Pre-Const.
		Approved: <i>R. Bloues</i> Chief Engineer